

Warranty

Amphenol Advanced Sensors warrants equipment of its manufacture to the original buyer against defective materials or workmanship for a period of one year from the date of shipment. The sensor element and calibration are not covered by this warranty.

All Amphenol Advanced Sensors RH and Temperature Products are fully tested and calibrated in accordance with the National Institute of Standards and Technology (NIST) prior to shipment. This is the highest quality calibration standard available.

Contact Information

To contact the factory, use the following information:

USA

Amphenol Thermometrics, Inc.
967 Windfall Road
St. Marys, Pennsylvania 15857
Web: www.amphenol-sensors.com

Mounting

The transmitter should be mounted:

- so that the 9 inch probe is in the center of the duct.
- 10 to 20 feet from the discharge of cooling coils and humidifiers.
- away from fans, duct corners, dampers and other equipment which will affect the measurement of relative humidity.
- in a location which will receive adequate air flow for proper operation.

For your convenience, the transmitter can be mounted using the full size mounting template included in this installation guide (see Figure 1 below).

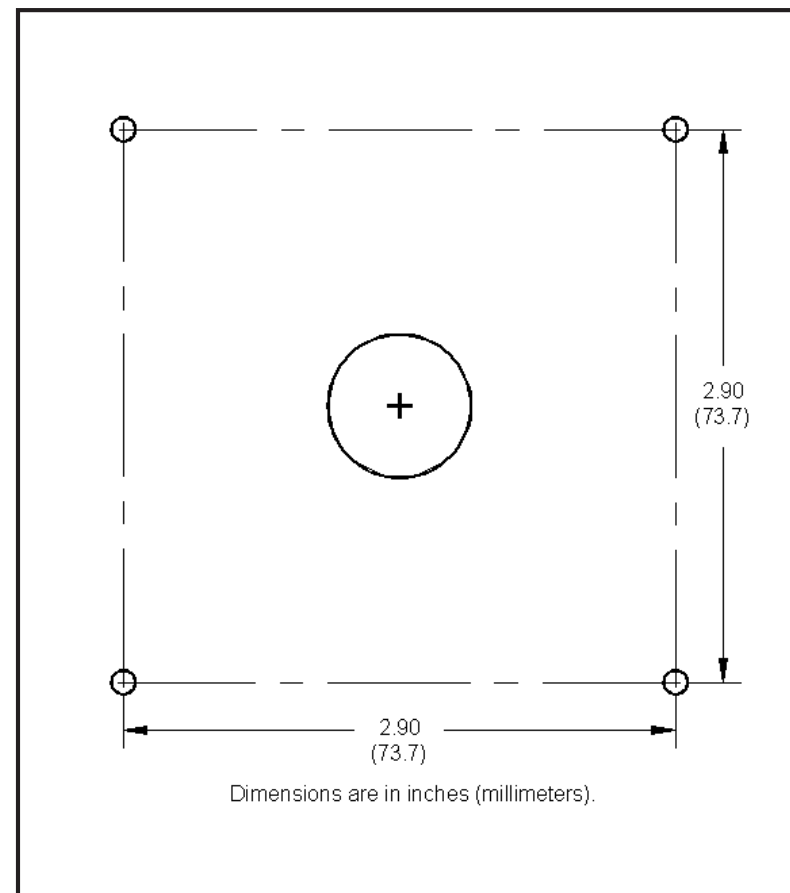

Figure 1: Duct Mounting Template - Full Size

Power Requirements

12-36 volts (DC only) power supply (furnished by the customer), capable of at least 20mA at the rated voltage for each transmitter.

$$\text{MaxLoad } \Omega = \frac{\text{Supply} - 10\text{VDC}}{0.02\text{A}} \text{ (for current output units)}$$

Wiring

Wiring for the transmitter should be a twisted pair, 16-22 AWG, approximately two turns per inch. In installations near electric motors or sensitive electronic equipment, use a shielded cable.

Relative Humidity - 4-20mA Current Output:

The 4 to 20mA transmitters will provide a linear proportional signal with 4mA corresponding to 0% RH and 20mA to 100% RH. These are loop-powered devices; therefore, only two wires are required. (See Figure 2 below for a wiring diagram.)

1. Connect the positive voltage (+) of the power supply to the RH transmitter screw terminal marked “+” or “P”.
2. Connect the RH transmitter screw terminal marked “-” or “N” to the (+) or (P) terminal of the data indicator device (i.e.: chart recorder, digital display energy management system).
3. Connect the (-) or (N) of the data indicator device to the negative (-) voltage terminal of the power supply.

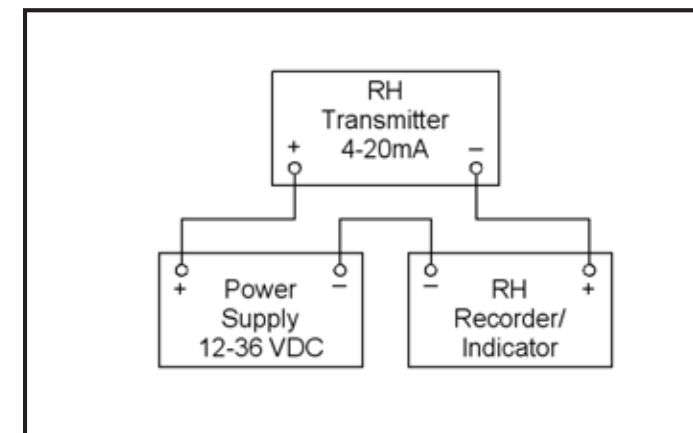

Figure 2: Connecting the RH - 4-20mA Current Output

Relative Humidity - 0-5V Voltage Output:

The 0 to 5V transmitters provide a linear proportional output at terminal OUT with 0 volts equivalent to 0% RH and 5 volts to 100% RH. The voltage output transmitters can be wired as a three-wire transmitter or as a four-wire transmitter to eliminate the effects of wire length. (See Figure 3 below for a wiring diagram.)

1. Connect the positive voltage (+) of the power supply to the RH transmitter screw terminal marked “+” or “P”.
2. Connect the negative voltage (-) of the power supply to the RH transmitter screw terminal marked “-” or “N”.
3. Connect the RH transmitter screw terminal marked “GND” to the (-) terminal of the data indicator device (i.e.: chart recorder, digital display, energy management system).
4. Connect the RH transmitter screw terminal marked “Out” to the (+) terminal of the data indicator device.

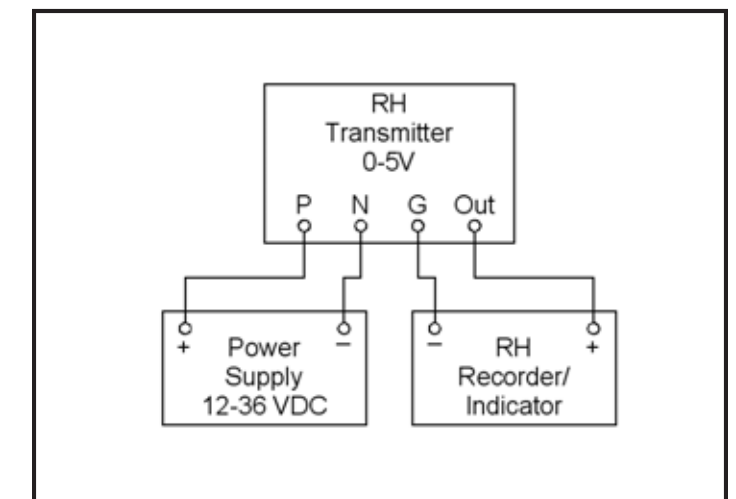

Figure 3: Connecting the RH - 0-5V Voltage Output

Temperature (Optional)

The temperature option (if ordered) is a separate circuit board mounted in the same housing above the relative humidity transmitter.

Note: *The temperature transmitter is available with 4-20mA current output only.*

The 4-20mA transmitter output is linear and proportional to the range specified when the transmitter was ordered. If no temperature range was specified, the temperature board is supplied with a range of -20° to +140°F. The low range temperature (4mA) is marked on the ZERO potentiometer and the high range temperature (20mA) is marked on the SPAN potentiometer.

The temperature transmitters are entirely separate circuits from the RH transmitters. The transmitters are loop-powered devices; therefore only two wires are required. One wire may be common with the RH transmitter. (See below for a wiring diagram.)

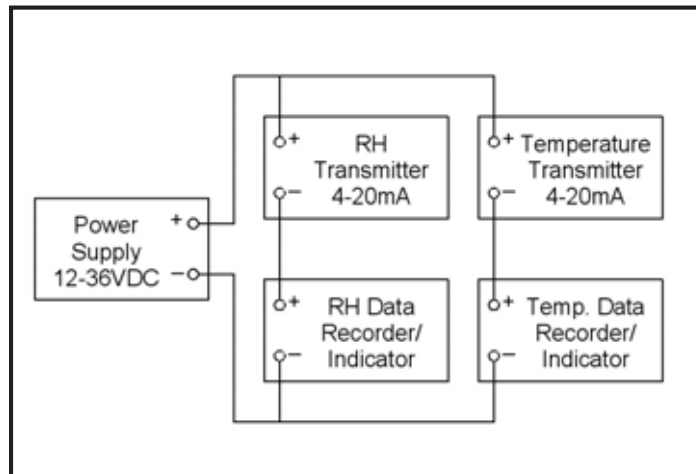

Figure 4: Connecting the Temperature Transmitter

Calibration

All Amphenol Advanced Sensors RH and Temperature products are fully tested and calibrated prior to shipment. If it is determined that the transmitter is giving an improper output signal, the unit may be field calibrated by following the calibration procedures below.

RH/RHT-2, -3, -5 - Current

Note: *Calibration potentiometers are labeled VR1 and VR2.*

For one point in place calibration, adjust VR1 (ZERO) until the transmitter output equals the output of a reference standard.

For more precise calibration, expose the sensor to a known 30% RH environment and adjust VR1 (ZERO). Adjust VR2 (SPAN) with the sensor in a known 80% RH environment.

RH-3 - Voltage

Note: *Calibration potentiometers are labeled VR1, VR2 and VR3.*

VR1 controls the gain for the entire span of the transmitter. However, unlike some transmitters, where gain is adjusted around a fixed zero reference point, VR1 adjusts gain around a fixed 100% output point. That is, adjusting VR1 will not change the output for 100% RH.

VR2 is an offset potentiometer. Moving it will shift the output at all humidities by the same amount.

VR3 is a trim potentiometer which affects only the gain below 60% RH. Adjusting VR3 can trim the low range output for improved accuracy.

RH-5 - Voltage

Note: *Calibration potentiometers are labeled VR1 and VR2.*

VR1 controls the gain for the entire span of the transmitter. However, unlike some transmitters, where gain is adjusted around a fixed zero reference point, VR1 adjusts gain around a fixed 100% output point. That is, adjusting VR1 will not change the output for 100% RH.

VR2 is an offset potentiometer. Moving it will shift the output at all humidities by the same amount.

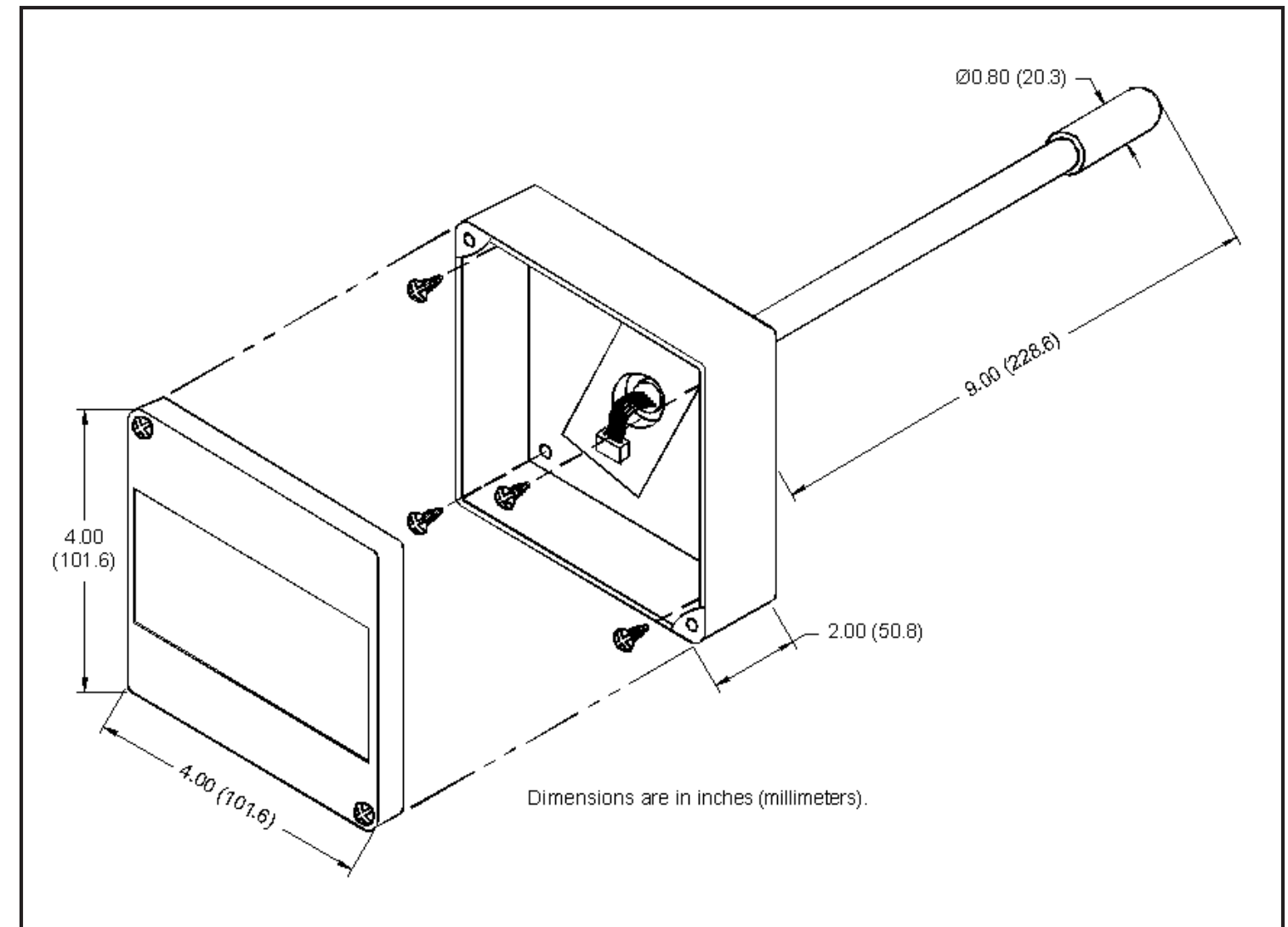

Figure 5: Duct Mount Dimensions