

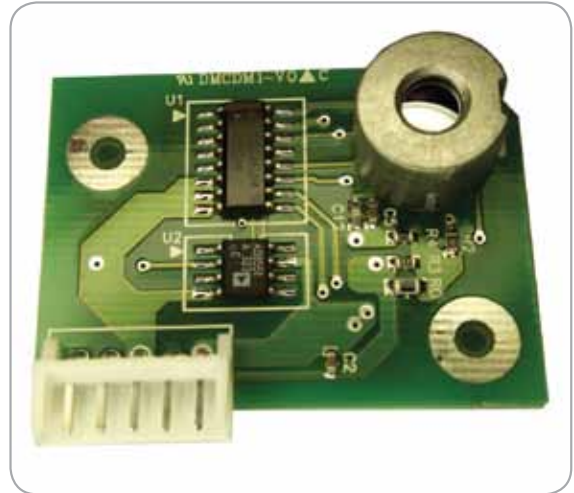

T H E R M O M E T R I C S
A C O M M I T M E N T T O E X C E L L E N C E

ZTP-25ASM

Thermometrics IR Model



The ZTP-25ASM model provides the temperature compensated quad outputs via two control signals with silicon optical lens. It can also provide a compatibility with the customer's device without the recalibration of the device. Five wire connections are necessary for operation: one for output signal, two signals for controlling the sensing elements, and two for single power supply and ground. The field of view of each element of ZTP-25ASM is about 4 degrees for 50% normalized output and the peak to peak of each element is about 8 degrees. The total size is only 1 in x 1.6 in (30 mm x 40 mm).

Applications

- Microwave ovens
- IR detector for multi-area detection

Features

- Easy application
- Compact size
- Ambient temperature-compensated output

Amphenol
Advanced Sensors

ZTP-25ASM Specifications

Supply Voltage

Single supply (+5V)

Supply Current

Typical 3.9 mA

Response Time

Maximum 35 ms

Range of Measuring Temperature

-58°F to 293°F (-50°C to 145°C)

Operating Temperature

-4°F to 212°F (-20°C to 100°C)

Storage Temperature

-4°F to 248°F (-20°C to 120°C)

Thermopile Sensor

ZTP-25A

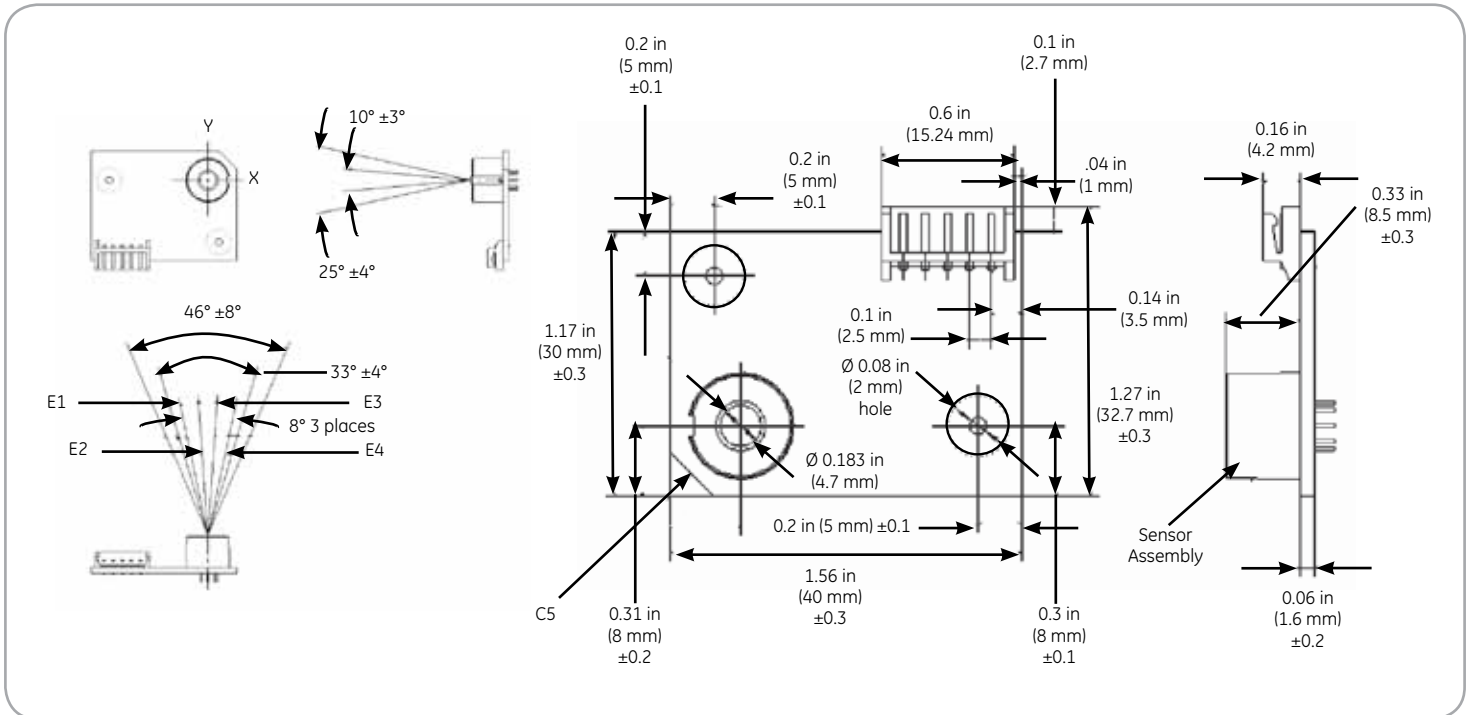
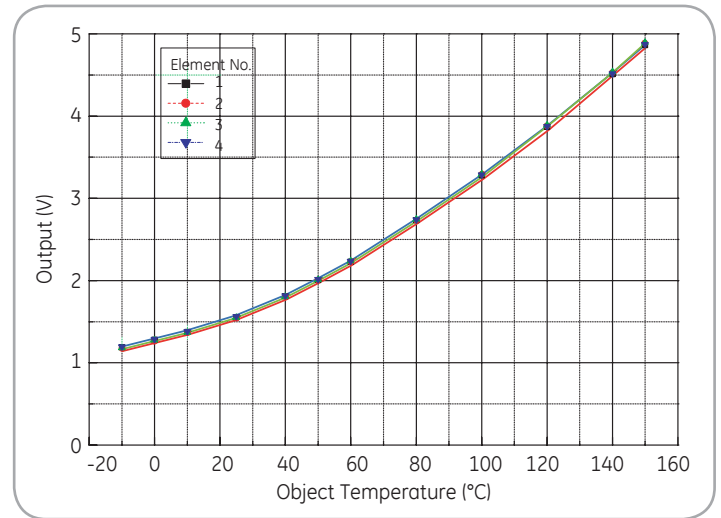

Field of view of sensor module and package dimensions

Amphenol
Advanced Sensors

www.amphenol-sensors.com

© 2014 Amphenol Corporation. All Rights Reserved. Specifications are subject to change without notice. Other company names and product names used in this document are the registered trademarks or trademarks of their respective owners.

AAS-920-161B-03/2014